

DS

Self Priming Centrifugal Pump



Model T6A3S-B

Size 6" x 6"



PUMP SPECIFICATIONS

- Size:** 6" x 6" (152 mm x 152 mm) NPT - Female.
- Casing:** Gray Iron 30.
Maximum Operating Pressure 79 psi (545 kPa).*
- Semi-Open Type, Two Vane Impeller:** Ductile Iron 65-45-12.
Handles 3" (76,2 mm) Diameter Spherical Solids.
- Impeller Shaft:** Alloy Steel 4150.
- Shaft Sleeve:** Alloy Steel 4130.
- Replaceable Wear Plate:** Carbon Steel 1026.
- Removable Adjustable Cover Plate:** Gray Iron 30; 62 lbs. (28 kg).
- Flap Valve:** Neoprene TM/Nylon and Steel Reinforcing.
- Seal Plate:** Gray Iron 30.
- Bearing Housing:** Gray Iron 30.
- Radial Bearing:** Open Single Row Ball.
- Thrust Bearing:** Open Double Row Ball.
- Bearing and Seal Cavity Lubrication:** SAE 30 Non-Detergent Oil.
- Flanges:** 125# Gray Iron 30.
- Gaskets:** Buna-N, Compressed Synthetic Fibers, PTFE, Vegetable Fiber, Cork, and Rubber.
- O-Rings:** Buna-N.
- Hardware:** Standard Plated Steel.
- Brass Pressure Relief Valve.**
- Bearing and Seal Cavity Oil Level Sight Gauges.**
- Optional Equipment:** Metal Bellows Seal. Automatic Air Release Valve. 120V/240V Casing Heater. High Pump Temperature Shutdown Kit. G-R Hard Iron Casing. Self-Cleaning Wear Plate. Gray Iron 30 Suction and Discharge Spool Flanges:
6" ASA (**Specify Model T6A3S-B /F**),
150 mm DIN 2527 (PN16) (**Specify Model T6A3S-B /FM**).

**Consult Factory for Applications Exceeding Maximum Pressure and/or Temperature Indicated.*



Shown with Optional Suction & Discharge Spool Flanges (Available in ASA or DIN Standard Sizes).

SEAL SPECIFICATIONS

Cartridge Type, Mechanical, Oil-Lubricated, Double Floating, Self-Aligning. Tungsten Titanium Carbide Rotating and Stationary Faces. Stainless Steel 316 Stationary Seat. Fluorocarbon Elastomers (DuPont Viton[®] or Equivalent). Stainless Steel 18-8 Cage and Spring. Maximum Temperature of Liquid Pumped, 160°F (71°C).*

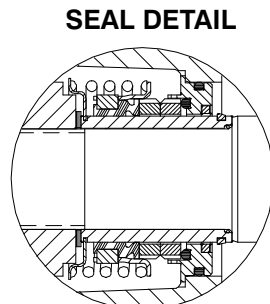
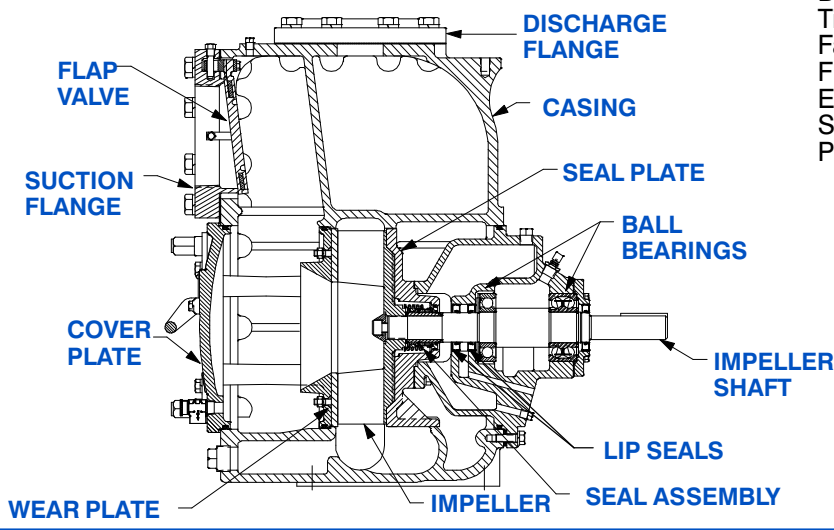

THE GORMAN-RUPP COMPANY • MANSFIELD, OHIO

GORMAN-RUPP OF CANADA LIMITED • ST. THOMAS, ONTARIO, CANADA

www.grpumps.com

Specifications Subject to Change Without Notice

Printed in U.S.A.

Specification Data

SECTION 55, PAGE 2200

APPROXIMATE DIMENSIONS and WEIGHTS

NET WEIGHT: 855 LBS. (388 KG.)*
SHIPPING WEIGHT: 910 LBS. (413 KG.)*
EXPORT CRATE: 32.5 CU. FT. (0,92 CU. M.)
***ADD 25 LBS. (11,3 KG.) W/EACH SPOOL FLANGE**

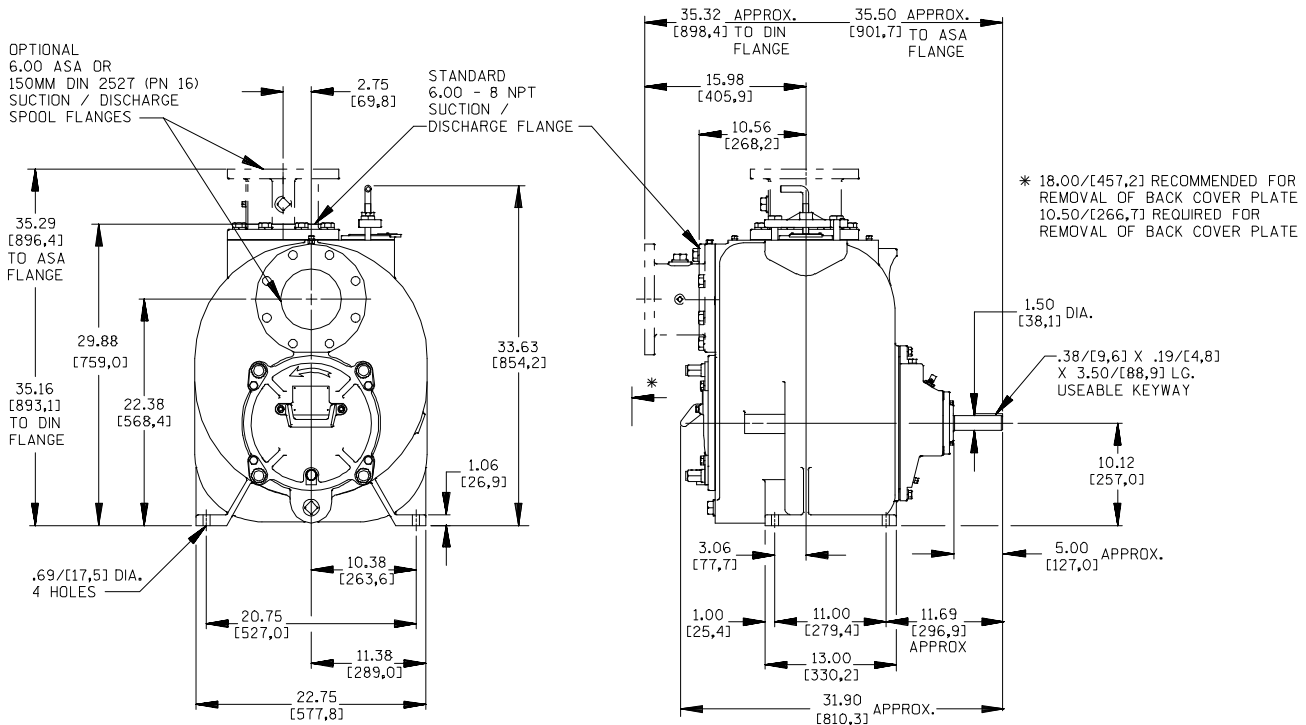

OPTIONAL ASA OR DIN STANDARD SUCTION & DISCHARGE SPOOL FLANGES AVAILABLE

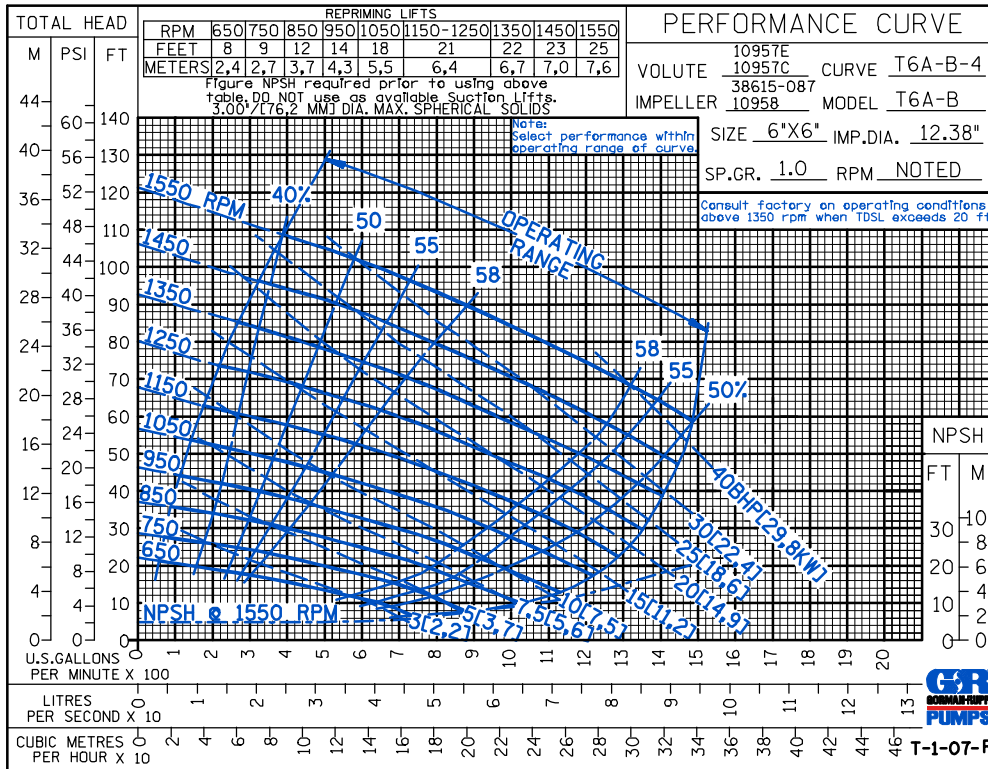

THE GORMAN-RUPP COMPANY • MANSFIELD, OHIO

GORMAN-RUPP OF CANADA LIMITED • ST. THOMAS, ONTARIO, CANADA

Specifications Subject to Change Without Notice

Printed in U.S.A.